

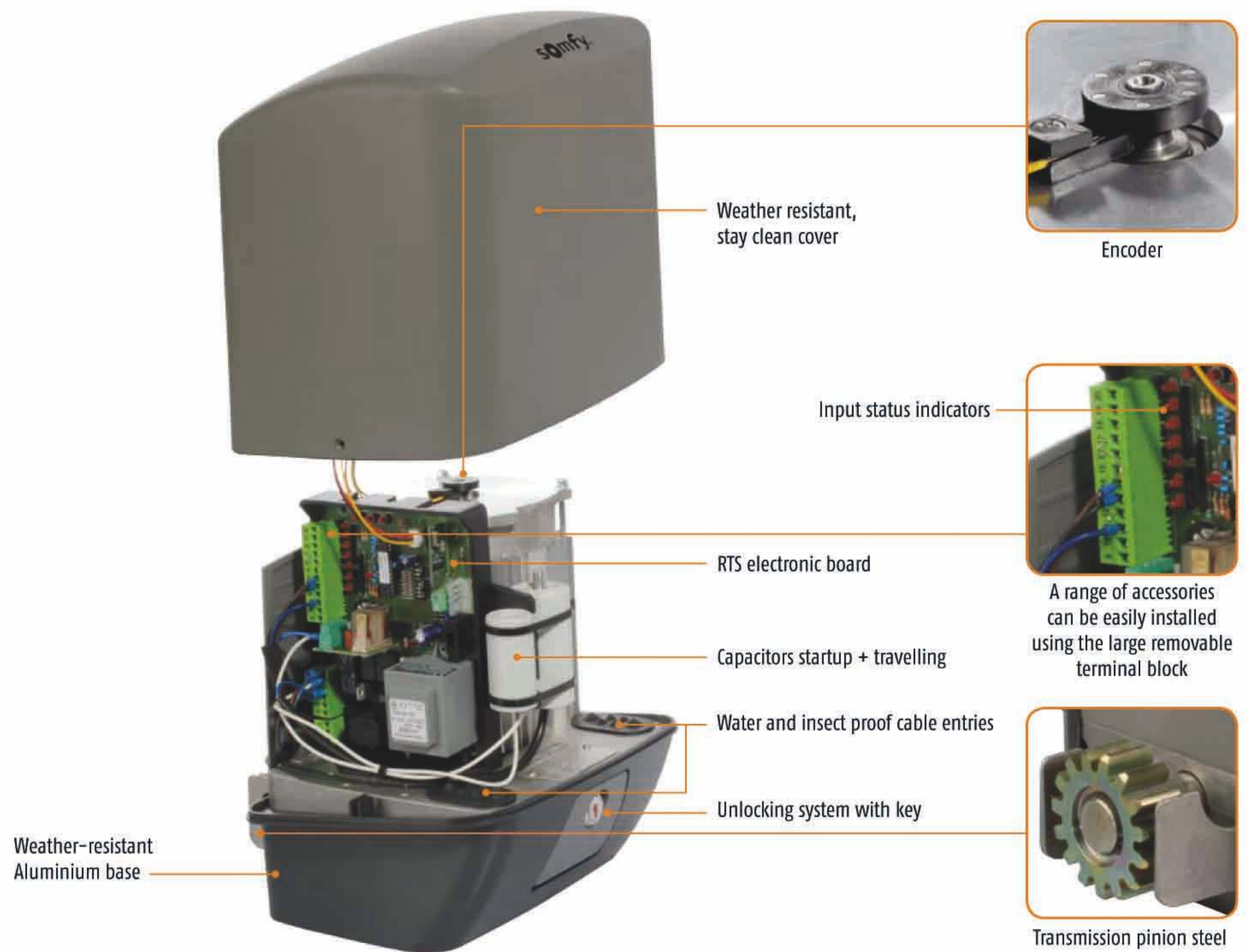

- **Robustness** for gate up to 2000kg in residential or commercial.
- Adjustable impact force.
- **Self learning programming system:** Adjustment of impact force and slow down phases.
- **Embedded position encoder** for precise management of course and slow down phases.
- **Mechanical declutching system** to open the gate manually.



OPTIONAL ACCESSORIES



Radio Keypad Metal RTS
ref. 1841116



230 V amber light
ref. 9015882



Photocells ref. 9014994
Protection cover ref. 9015132



1 meter steel rack
ref. 9011069

GENERAL OVERALL SIZE

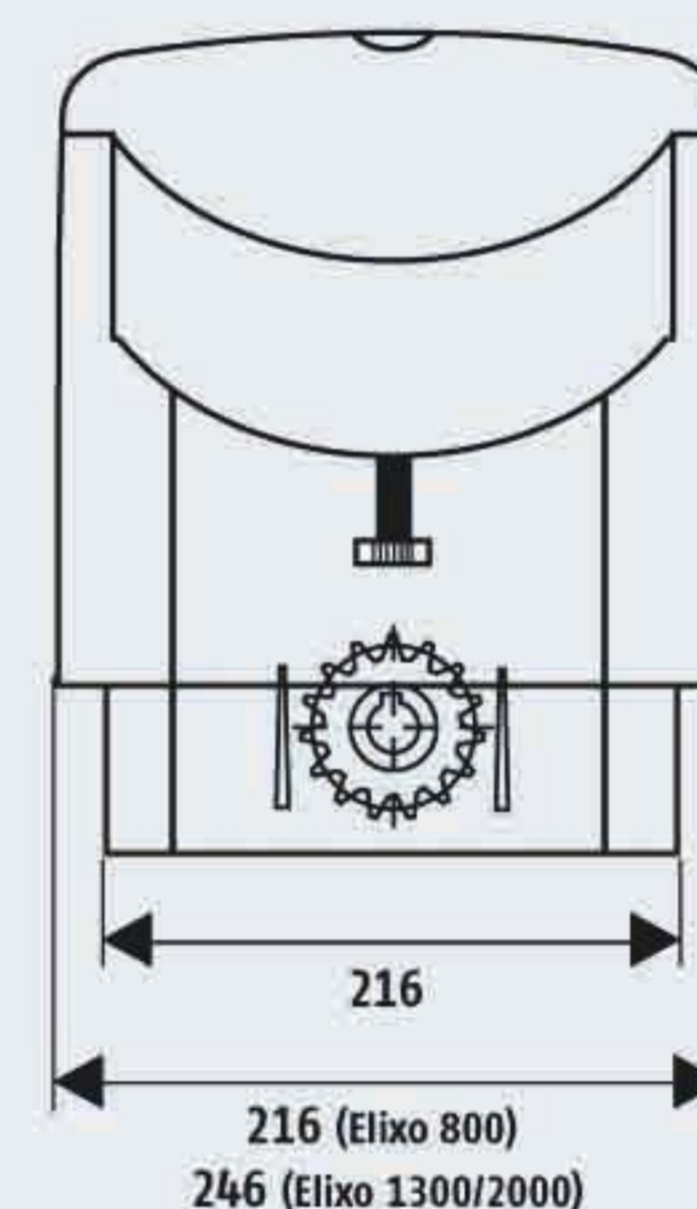
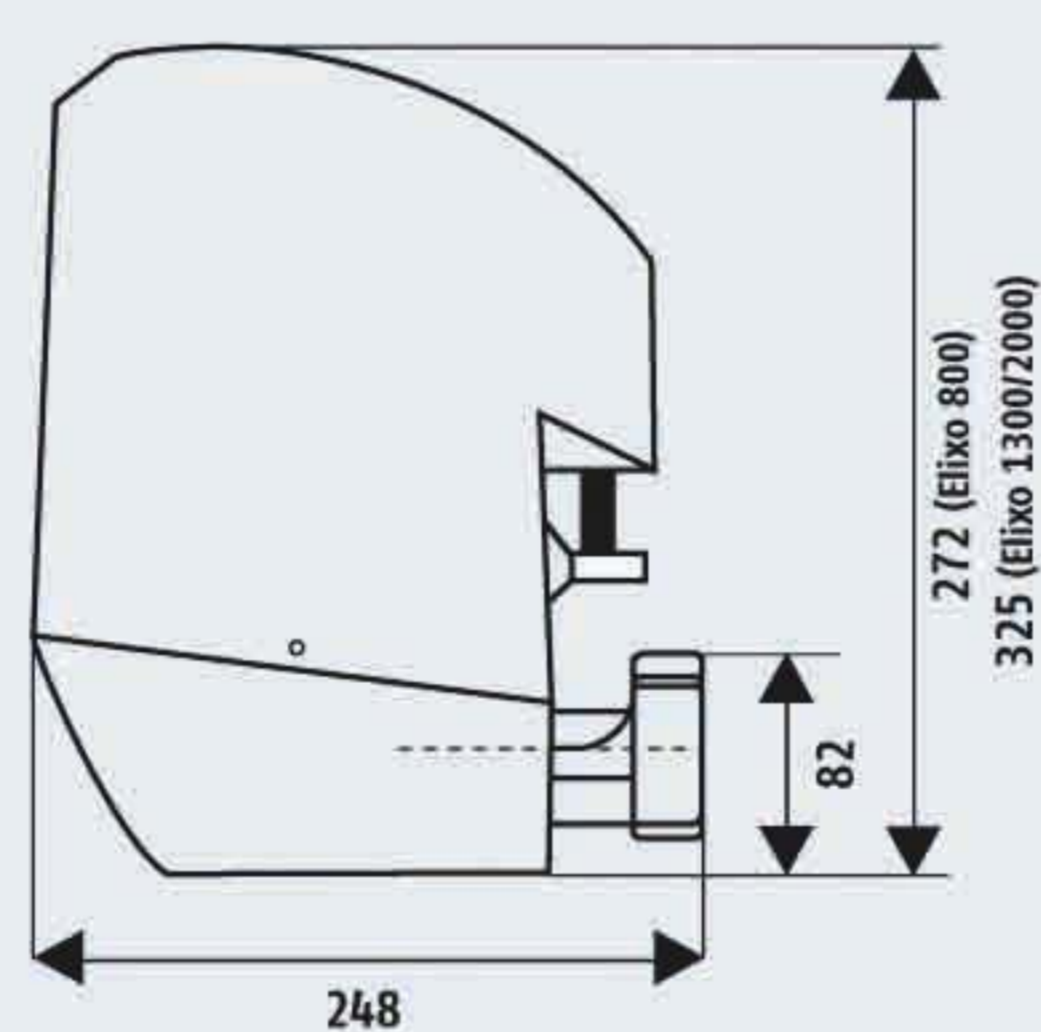

TECHNICAL CHARACTERISTICS	230V ELIXO 800 KIT STANDARD	230V ELIXO 1300 KIT STANDARD	230V ELIXO 2000 KIT STANDARD
Maximum weight of the gate	800 Kg	1300 Kg	2000 Kg
Motor power supply	230 V - 50 Hz		
Power consumption	240 W	260 W	270 W
Speed	10 m/min		
Impact force	Electronic detection adjustable		
Slowing zone	Adjustable gate travel - Adjustable impact force		
Number of cycles	Max per day: 100 - Heating protection: 150° C Max consecutive: 12 cycles for 7m course & 6 cycles for 10 m course		
Motor working time - Max safety time	300 s		
Gear reduction ratio	1/28		
Max number of operation per day	100		
Operating temperature	-20°C to +60°C		
Protection factor	IP 44		
Area lighting	230 Vac - 100 W max. - Area lighting time: fixed 90 seconds		